

PLOW BOLTS - PLAIN FINISH GRADE 5 & GRADE 8

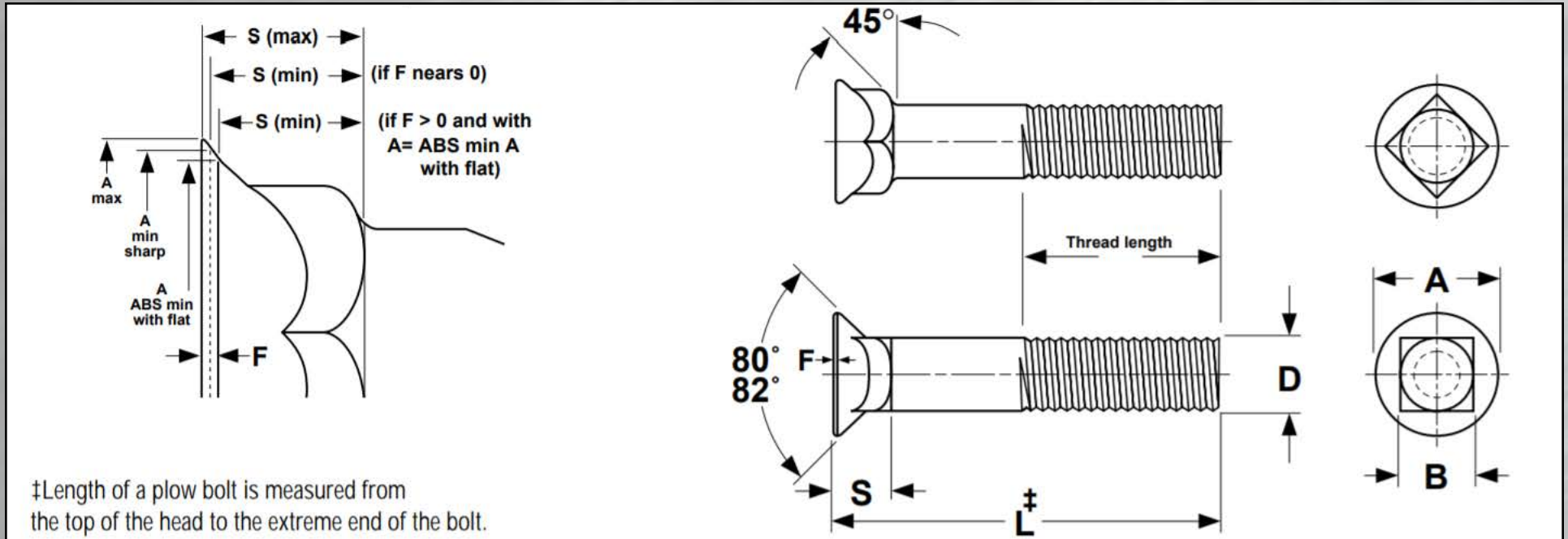



545 Basket Road • Webster, NY 14580
 Toll Free • 800.691.0292 | Local • 585.265.1990 | Fax • 585.265.6678
 sales@fastenersdirect.com
 www.fastenersdirect.com

PLOW BOLTS - PLAIN FINISH GRADE 5 & GRADE 8

Number 3 Head Plow Bolts										
D Nominal Diameter	E Diameter of Full Size Body		A Diameter of Head			F Feed Thickness	S Depth of Square and Head		B Width of Square	
	Max	Min	Max	Min Sharp	Abs. Min with Flat	Max	Max	Min	Max	Min (Basic)
	5/16	0.312	0.299	0.605	0.578	0.563	0.025	0.269	0.243	0.325
3/8	0.375	0.360	0.708	0.671	0.656	0.031	0.312	0.281	0.387	0.375
7/16	0.438	0.421	0.826	0.781	0.766	0.036	0.364	0.328	0.450	0.438
1/2	0.500	0.483	0.945	0.890	0.875	0.042	0.417	0.375	0.515	0.500
5/8	0.657	0.606	1.147	1.094	1.063	0.050	0.506	0.456	0.640	0.625
3/4	0.782	0.729	1.303	1.250	1.219	0.050	0.541	0.491	0.765	0.750
7/8	0.938	0.853	1.512	1.469	1.406	0.063	0.626	0.563	0.906	0.875
1	1.062	0.976	1.700	1.656	1.594	0.063	0.690	0.627	1.031	1.000

Tolerance on Length	Nominal Bolt Size	All lengths
	1/4 through 3/8	+/- 0.03
	7/16 and 1/2	+/- 0.06
	5/8 through 1	+/- 0.12



545 Basket Road • Webster, NY 14580
 Toll Free • 800.691.0292 | Local • 585.265.1990 | Fax • 585.265.6678
 sales@fastenersdirect.com
 www.fastenersdirect.com

PLOW BOLTS - PLAIN FINISH GRADE 5 & GRADE 8

Minimum Thread Length of Plow Bolts (2D + 0.25)								
Recommended Bolt Length	Nominal Bolt Diameter							
	5/16	3/8	7/16	1/2	5/8	3/4	7/8	1
1	T to H	T to H	-	-	-	-	-	-
1-1/4	0.875	T to H	T to H	T to H	T to H	-	-	-
1-1/2	0.875	1.000	T to H	T to H	T to H	T to H	T to H	-
1-3/4	0.875	1.00	1.125	1.250	T to H	T to H	T to H	T to H
2	0.875	1.000	1.125	1.250	T to H	T to H	T to H	T to H
2-1/4	0.875	1.000	1.125	1.250	1.500	T to H	T to H	T to H
2-1/2	0.875	1.000	1.125	1.250	1.50	1.750	T to H	T to H
3	0.875	1.000	1.125	1.250	1.50	1.750	2.000	2.250
3-1/2	0.875	1.000	1.125	1.250	1.500	1.750	2.000	2.250
4	0.875	1.000	1.125	1.250	1.500	1.750	2.000	2.250



545 Basket Road • Webster, NY 14580
 Toll Free • 800.691.0292 | Local • 585.265.1990 | Fax • 585.265.6678
 sales@fastenersdirect.com
 www.fastenersdirect.com

PLOW BOLTS - PLAIN FINISH GRADE 5 & GRADE 8

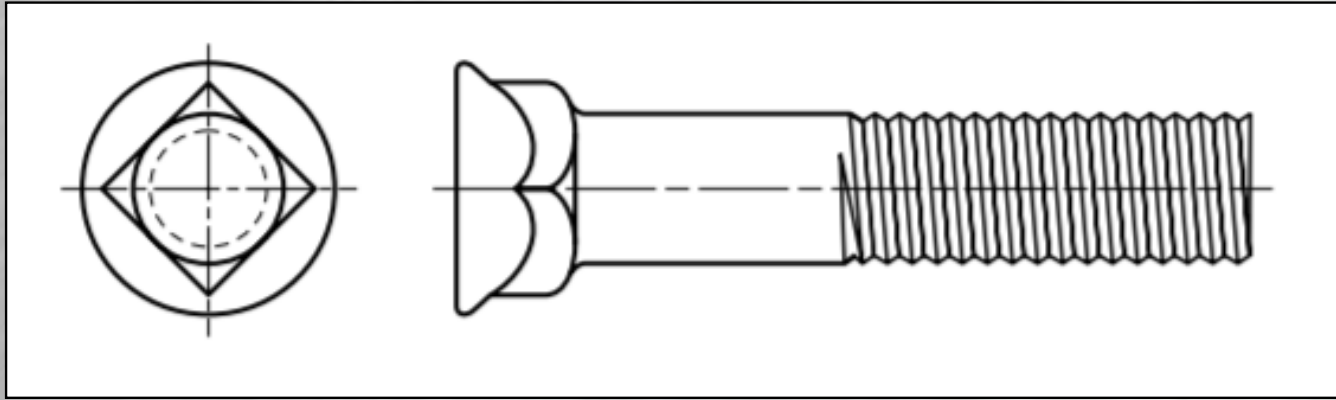

Description	Bolt with a countersunk, flat head, square neck and unified thread pitch, made from medium-carbon steel
Applications / Advantages	Used in road graders, scoops, shovels, and other heavy-duty equipment where a smooth surface is required at the spot of the head protrusion.
Material	Grade 5 plow bolts shall be made from a medium carbon steel which conforms to the following chemical composition requirements: <ul style="list-style-type: none"> • Carbon: 0.28% to 0.55% • Phosphorus: 0.048% maximum • Sulfur: 0.058% maximum
Heat Treatment	Grade 5 plow bolts shall be heat treated, oil or water quenched, and tempered at a minimum tempering temperature of 800* F
Core Hardness	Rockwell C25 - C34
Surface Hardness	Rockwell 30N 54 Maximum
Proof Load	85,000 psi
Yield Strength	92,000 psi minimum
Tensile Strength	120,000 psi minimum



545 Basket Road • Webster, NY 14580
Toll Free • 800.691.0292 | Local • 585.265.1990 | Fax • 585.265.6678
sales@fastenersdirect.com
www.fastenersdirect.com

PLOW BOLTS - PLAIN FINISH GRADE 5 & GRADE 8

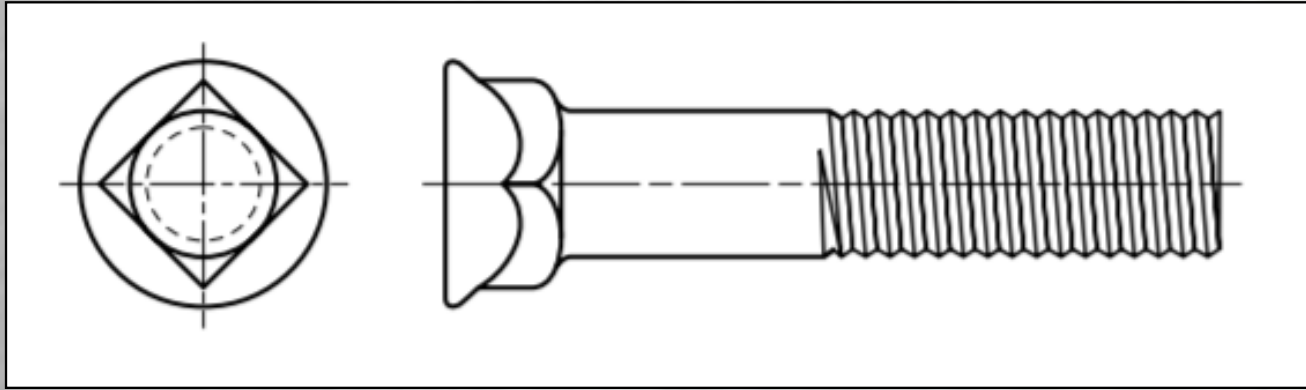

Description	A plow bolt made from ally steel.
Applications / Advantages	Greater tensile and proof load strength than a grade 5 bolt. Poplular use is with bulldozers and snowplow blades.
Material	AISI 4037 and 4042 steel
Heat Treatment	Grade 8 plow bolts shall be heat treated, oil quenched and tempered at a minimum tempering temperature of 800* F
Core Hardness	Rockwell C33 - C39
Surface Hardness	Rockwell 30N58.6 maximum
Proof Load	120,000 psi
Yield Strength	130,000 psi minimum
Tensile Strength	150,000 psi minimum